

AZARAN

Transfer Machines & Automations

Since 1984

4th Edition - 2024





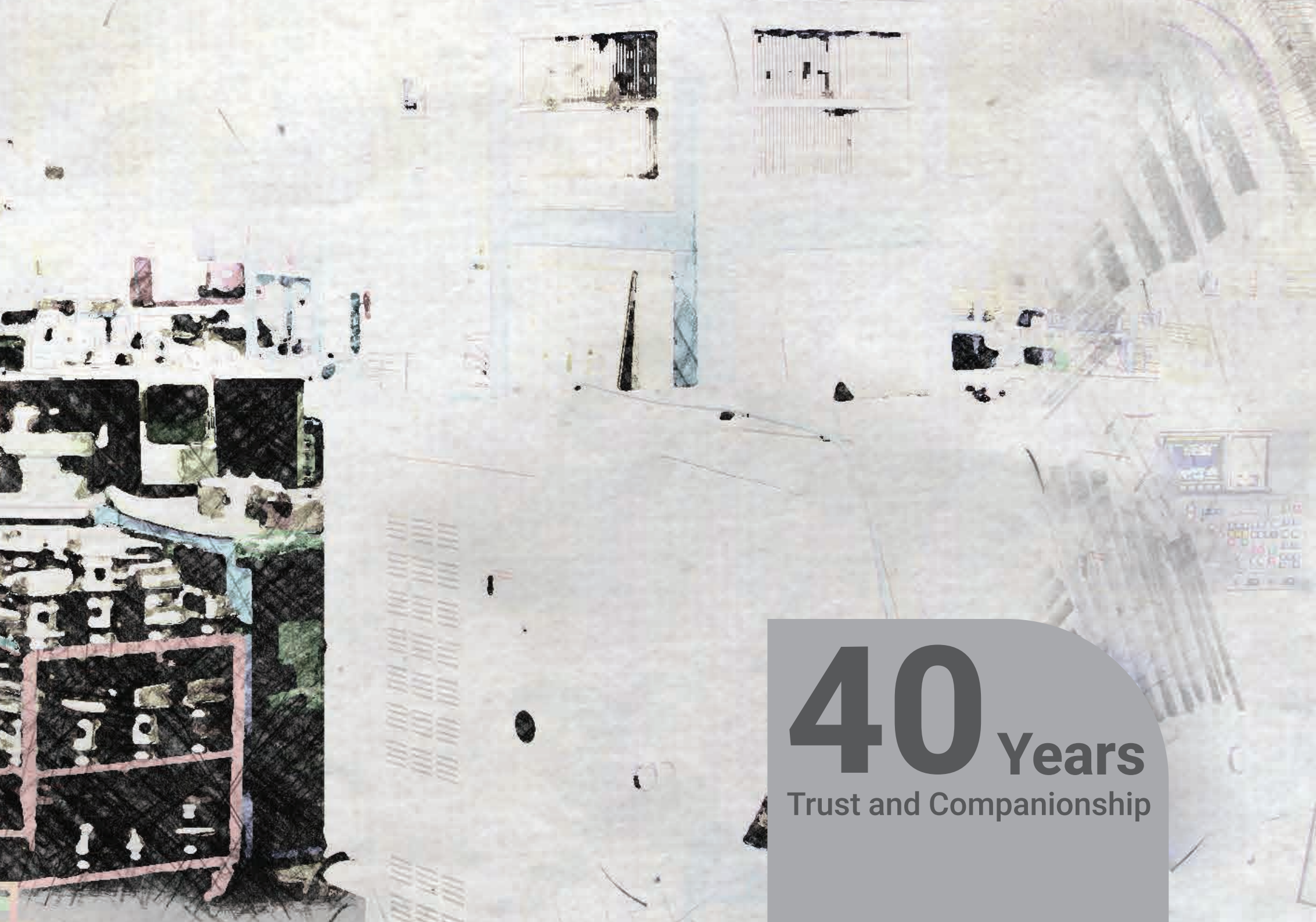

40 Years
Trust and Companionship

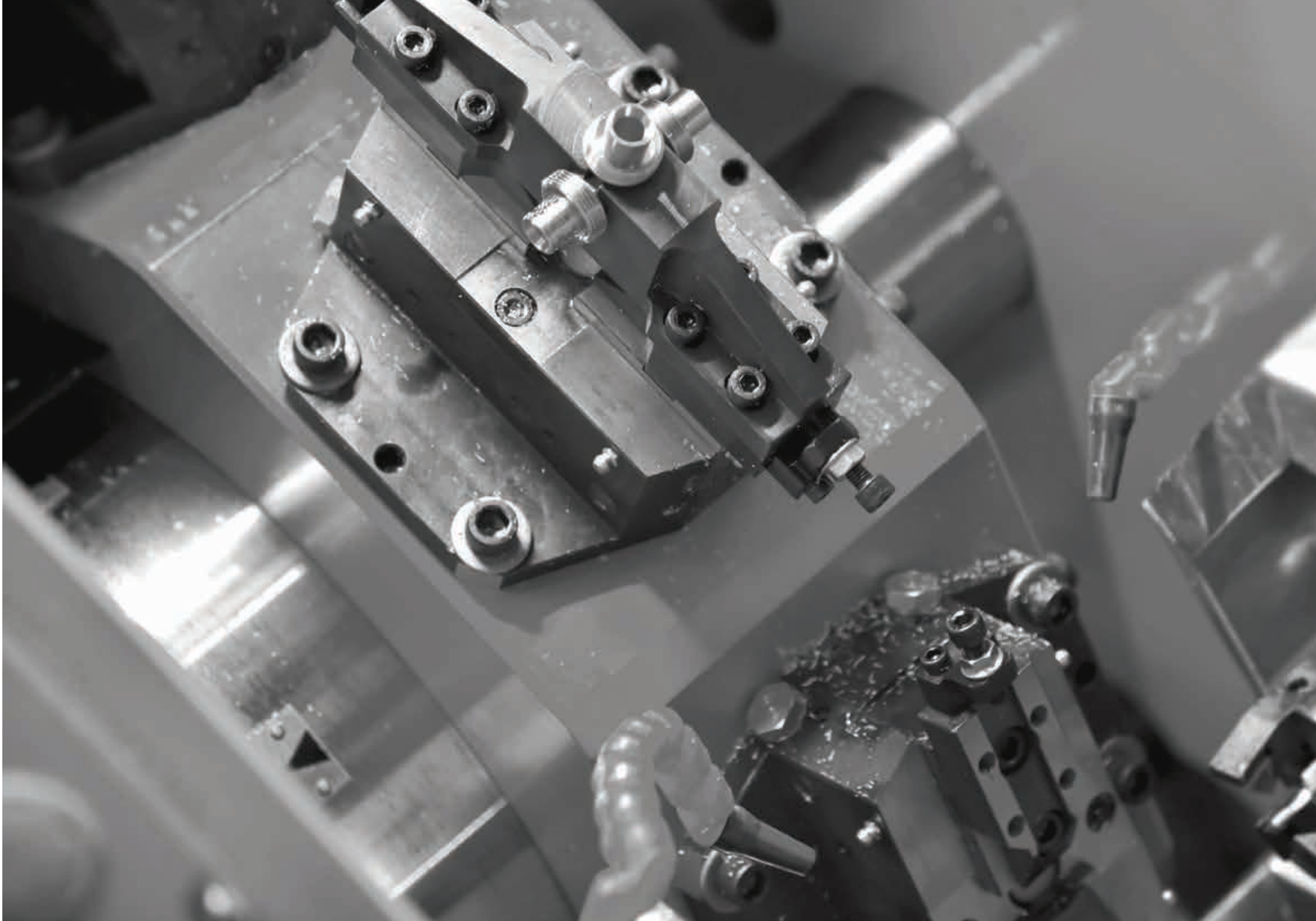



AZARAN Industrial group

Azaran Industrial Group was founded in 1984 with the goal of manufacturing industrial components. Through relentless effort and determination, the company quickly secured its position in the market and expanded its operations to include the production of brass valves and fittings, multi-layer pipes, and the establishment of related production lines. The company's strategic focus has consistently been on research and development, innovation, and continuous training. This approach has positioned Azaran as one of the leaders in Iran's brass valve and fitting industry. Our ongoing efforts have led to the creation of the largest and most advanced brass product manufacturing facilities in Iran under the "Azar" brand, as well as Iran's first production facilities for transfer machines and related equipment under the "Azaran" brand.

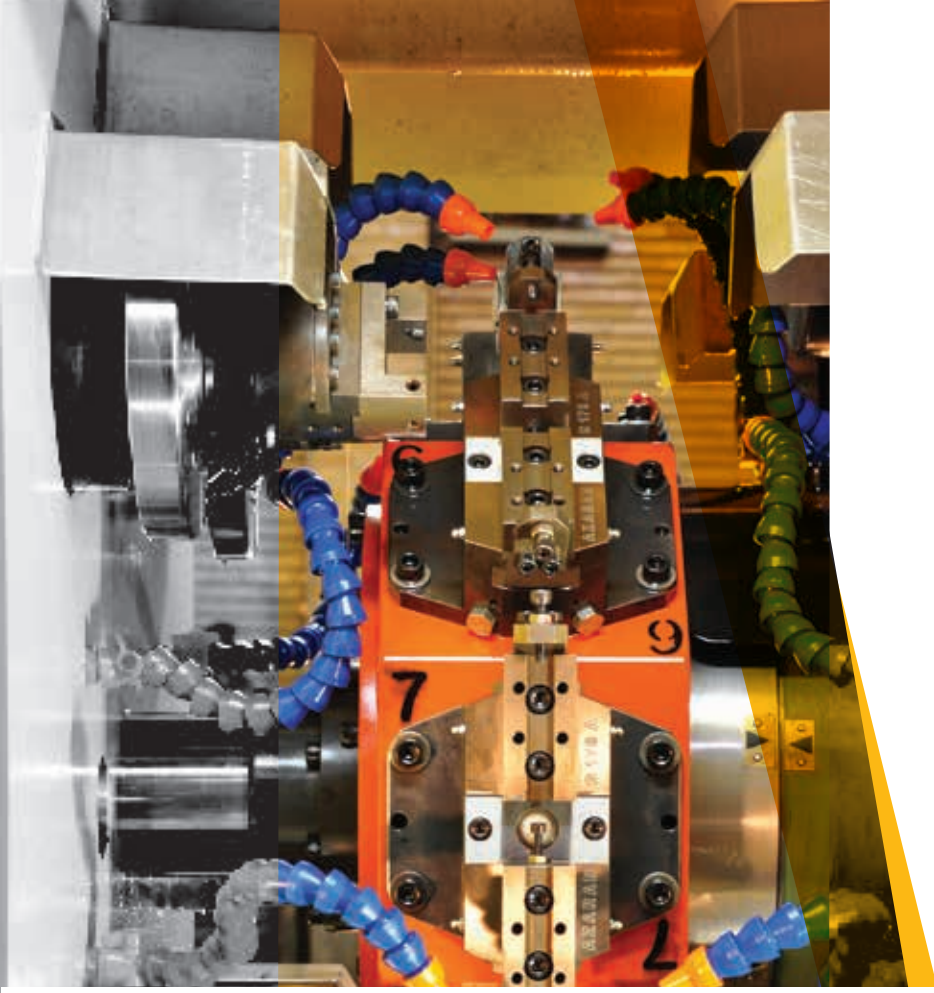

SIEMENS

Telemecanique

Schneider
Electric

PHOENIX
CONTACT



ROTARY TRANSFER MACHINES



HTM408V

Vertical Transfer Machine - 8 stages



HTM408V

Number of Unit	on Request- Max. 19
Index Type	ITH400
Machining Units Type	HBU95/150 - HRU95 - TU75
Gripper Type	G170A/G255A
Control System	PLC & HMI (Siemens - S7)
Power System	Hydraulic-Pneumatic
Lubrication System	Automatic
Coolant System	<input checked="" type="checkbox"/>
Chip Conveyor System	<input checked="" type="checkbox"/>
Approx. Weight (With 10 Machining Units)	7000 kg
Dimensions (Without Electrical Cabinet)	2450x2300x3250 (LxWxH)

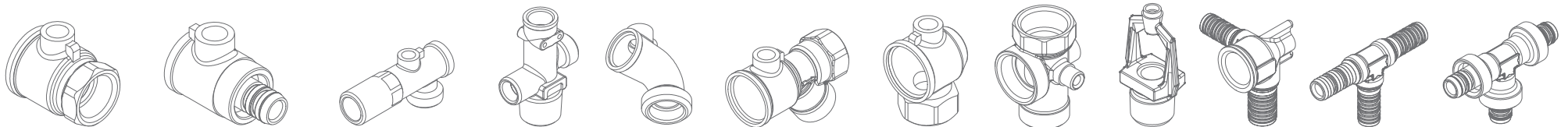

HTM406V

Vertical Transfer Machine - 6 stages

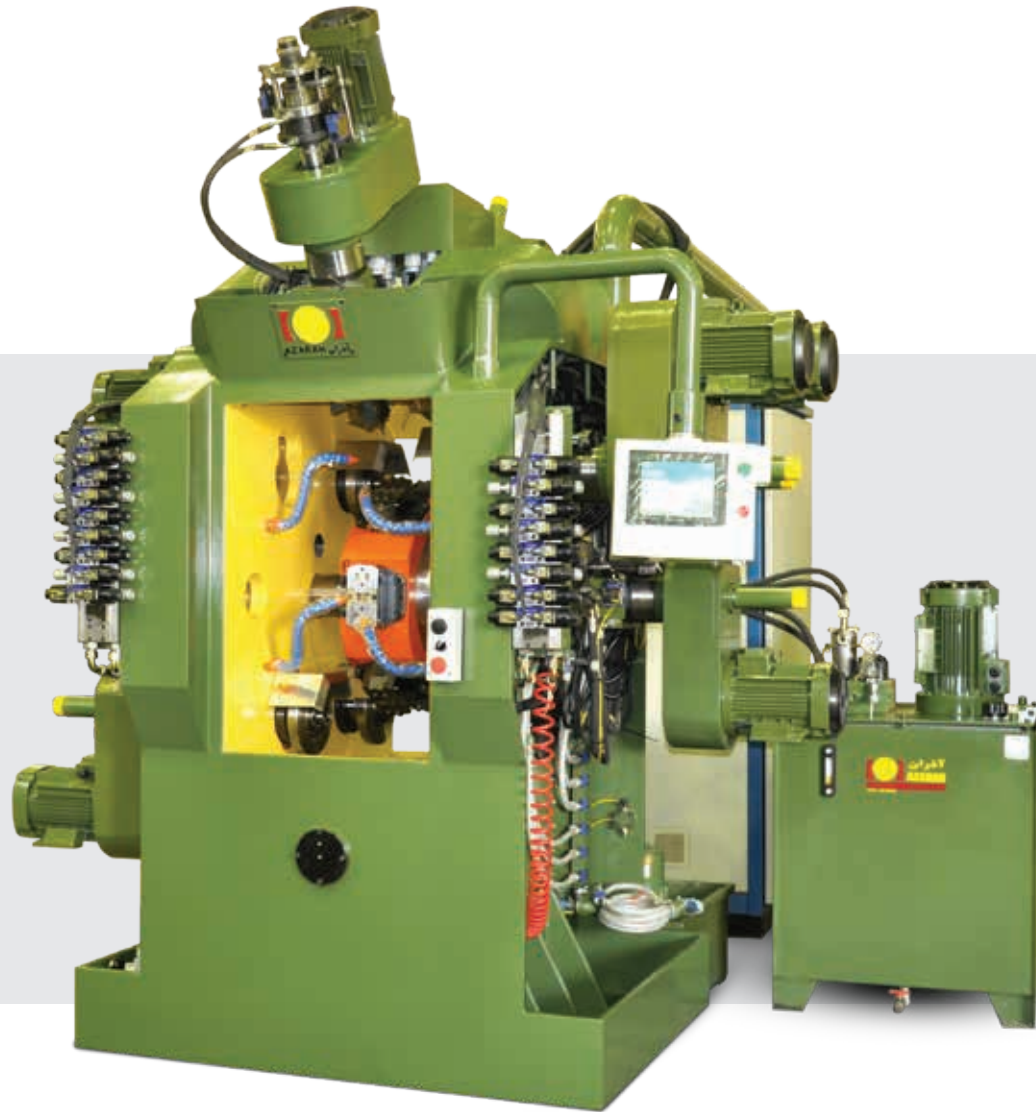

HTM406V

Number of Unit	on Request- Max. 13
Index Type	ITH400
Machining Units Type	HBU95/150 - HRU95 - TU75
Gripper Type	G170A/G255A
Control System	PLC & HMI (Siemens - S7)
Power System	Hydraulic-Pneumatic
Lubrication System	Automatic
Coolant System	<input checked="" type="checkbox"/>
Chip Conveyor System	<input checked="" type="checkbox"/>
Approx. Weight (With 10 Machining Units)	5500 kg
Dimensions (Without Electrical Cabinet)	2300x2300x2830 (LxWxH)

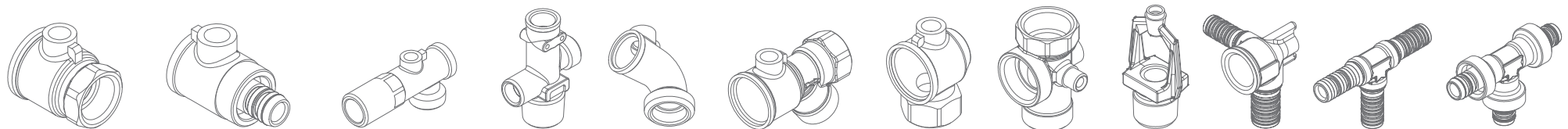

HTM40-HD

Horizontal Transfer Machine (Double)



HTM40-HD

Number of Station	4 - 6 - 8
Number of Unit	on Request
Index Type	ITH400
Machining Units Type	HBU95/150 - HRU95 - TU75
Gripper Type	G170A/G255A
Control System	PLC & HMI (Siemens - S7)
Power System	Hydraulic-Pneumatic
Lubrication System	Automatic
Coolant System	<input checked="" type="checkbox"/>
Approx. Weight (With 5 Machining Units)	4300 kg
Dimensions (Without Electrical Cabinet)	3000x2550x2400 (LxWxH)



HTM40-H

Horizontal Transfer Machine



HTM40-H

Number of Station	4 - 6 - 8
Number of Unit	On request
Index Type	ITH400
Machining Units Type	HBU95/150 - HRU95 - TU75
Gripper Type	G170A/G255A
Control System	PLC & HMI (Siemens - S7)
Power System	Hydraulic-Pneumatic
Lubrication System	Automatic
Coolant System	<input checked="" type="checkbox"/>
Approx. Weight (With 5 Machining Units)	2900 kg
Dimensions (Without Electrical Cabinet)	2700x2500x1950 (LxWxH)

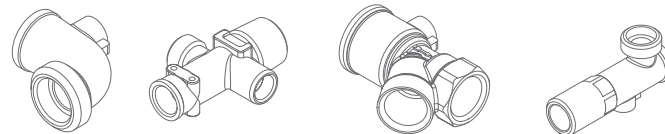



PNEUMATIC CHUCKS

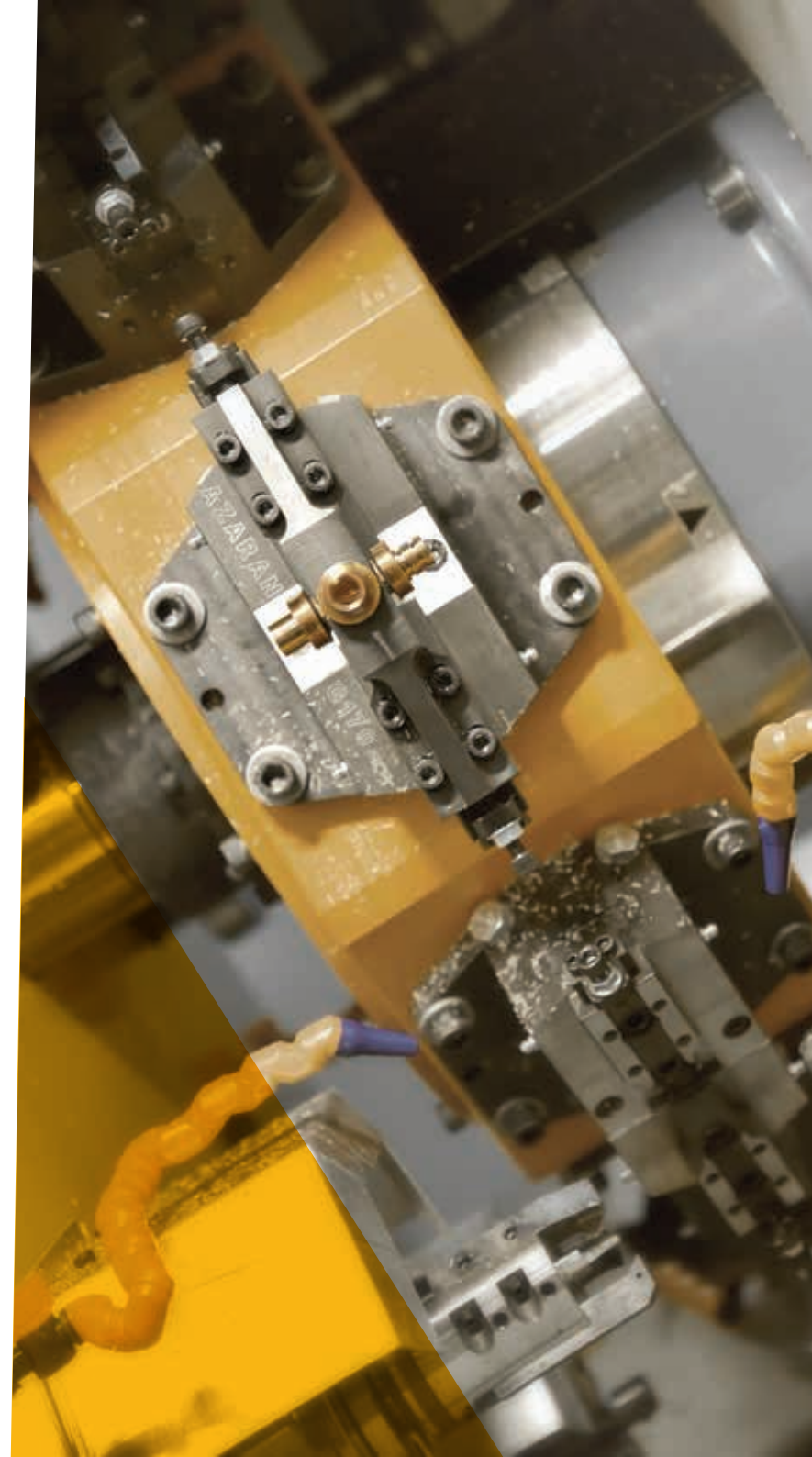

G85A G110A G140A G170A G225A

2-Jaw Pneumatic Chuck – Type A

G85A G110A G140A G170A G255A

Total Stroke	9 mm	10 mm	15 mm	17 mm	28 mm
Nominal Clamping Force at 6 bar	1400 N	2300 N	3600 N	6000 N	12500 N
Approx. Weight	2 kg	4.5 kg	9 kg	14.5 kg	49 kg

ITEM	G85A	G110A	G140A	G170A	G255A
A	ø80 h6	ø106 h6	ø130 h6	ø155 h6	ø232 h6
B	ø14	ø16	ø20	ø25	ø38
C	73	91	117	138.5	202.5
D	42 ±0.05	57 ±0.05	72.4 ±0.05	84 ±0.05	126 ±0.05
E	5.5	5.5	5	6	6
F	5	6	7.4	8	12
G	3.6	3.8	3.5	4	4.5
H	8H7	10H7	12H7	16H7	18H7
I (MAX)	96	125	158	184	277
I (MIN)	87	115	143	167	249
J	20 h6	26 h6	34 h6	40 h6	60 h6
K	45	60	75	90	135
L	90	118	144	172	257
M	84	110	135	159	220
N	40	55	65	89	140
O	20	25	33	40	60
P	M6	M8	M8	M10	M12
Q	ø6.5	ø8.5	ø11	ø15	ø18
R	ø6H7	ø8H7	ø10H7	ø10H7	ø16H7
S	M6	M6	M6	M6	M6
T	M5xø6	1/8" x ø6	1/8" x ø6	1/4" x ø6	1/4" x ø10
U	6	7.5	8.5	11	16.5
V	40	50	62.5	73	109.5
W	12	15	19	23	37.5
X	100	130	160	188	282
Y	9	11	13.4	15	22.5
Z	M4	M5	M6	M6	M8

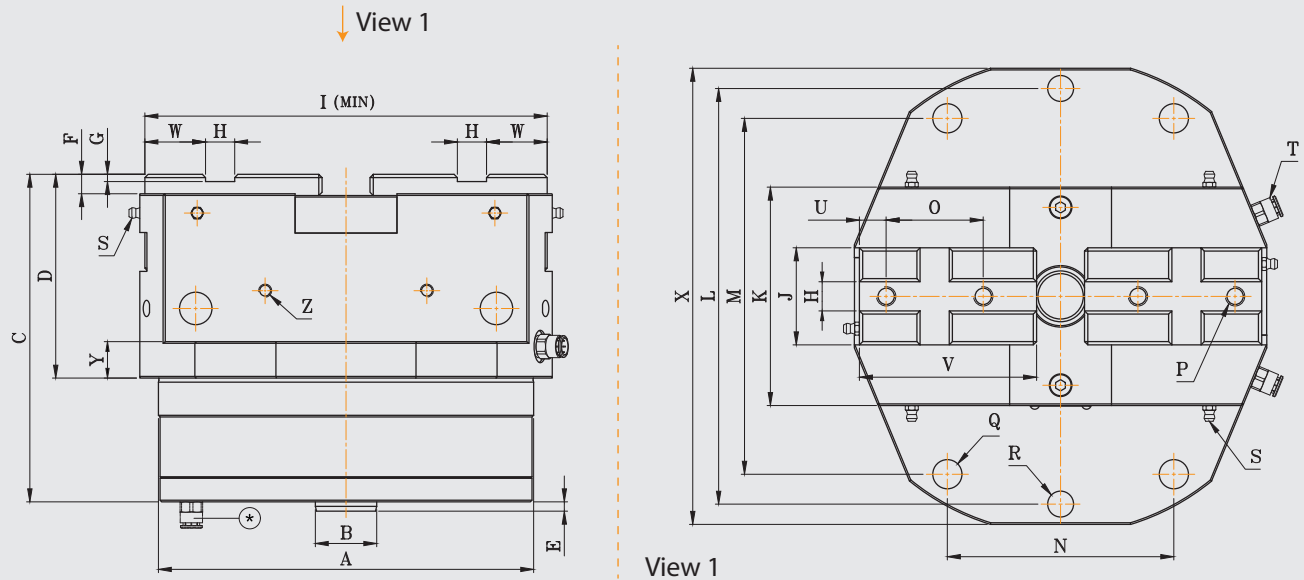

- ✳ Double port option for clamping power
- Mounting holes (Z) for part stop or reference



G60B G85B G85BD G110B G140B G170B G255B

2-Jaw Pneumatic Chuck – Type B

	G60B	G85B	G85BD	G110B	G140B	G170B	G255B
Total Stroke	5 mm	9 mm	19 mm	10 mm	15 mm	17 mm	28 mm
Nominal Clamping Force at 6 bar	600 N	140 N	700 N	2300 N	3600 N	6000 N	12500 N
Approx. Weight	1 kg	2 kg	2.5 kg	4.5 kg	9 kg	15 kg	52 kg

ITEM	G60B	G85B	G85BD	G110B	G140B	G170B	G255B
A	∅58 _{h6}	∅85 _{h6}	∅85 _{h6}	∅112 _{h6}	∅138 _{h6}	∅168 _{h6}	∅255 _{h6}
B	–	∅14	∅14	∅16	∅20	∅25	∅38
C	60 ±0.05	73 ±0.05	85 ±0.05	91 ±0.05	117 ±0.05	138 ±0.05	203 ±0.05
D	30.5	40	40	45	58	69	99.5
E	–	5.5	5.5	5.5	5	6.3	5.3
F	4.5	5	5	6	7.4	8	12
G	2.5	3.6	3.6	3.8	3.5	4	4.5
H	6 H7	8 H7	8 H7	10 H7	12 H7	16 H7	18 H7
I (MAX)	63.5	95.5	104	124.5	157.5	184	277
I (MIN)	58.5	86.5	85	114.5	142.5	167	249
J	15 _{h6}	20 _{h6}	20 _{h6}	26 _{h6}	34 _{h6}	40 _{h6}	60 _{h6}
K	32	45	45	60	75	90	135
L	48	72	72	95	120	145	220
M	42	58.3	58.3	77	97	107	170
N	24	42.3	42.3	56	70.5	99	140
O	14	20	20	25	33	40	60
P	M4	M6	M6	M8	M8	M10	M12
Q	∅6	∅6.5	∅6.5	∅8.5	∅11	∅11	∅18
R	∅5 H7	∅6 H7	∅6 H7	∅8 H7	∅10 H7	∅10 H7	∅16 H7
S	M6	M6	M6	M6	M6	M6	M6
T	M5x∅4	M5x∅6	M5x∅6	1/8" x ∅6	1/8" x ∅6	1/4" x ∅6	1/4" x ∅10
U	4	6	6	7.5	8.5	11	16.5
V	28	40	42	50	62.5	73	109.5
W	8	12	12	15	19	23	37.5
X	–	M4	M4	M5	M6	M6	M6

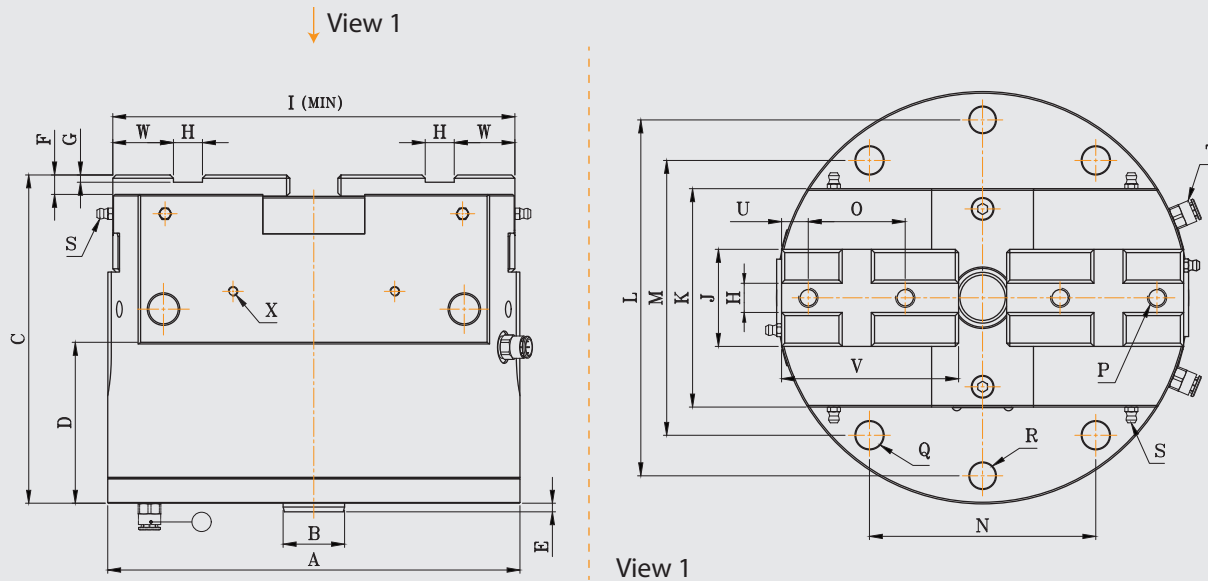

- ✳ Double port option for clamping power
- Mounting holes (X) for part stop or reference

*

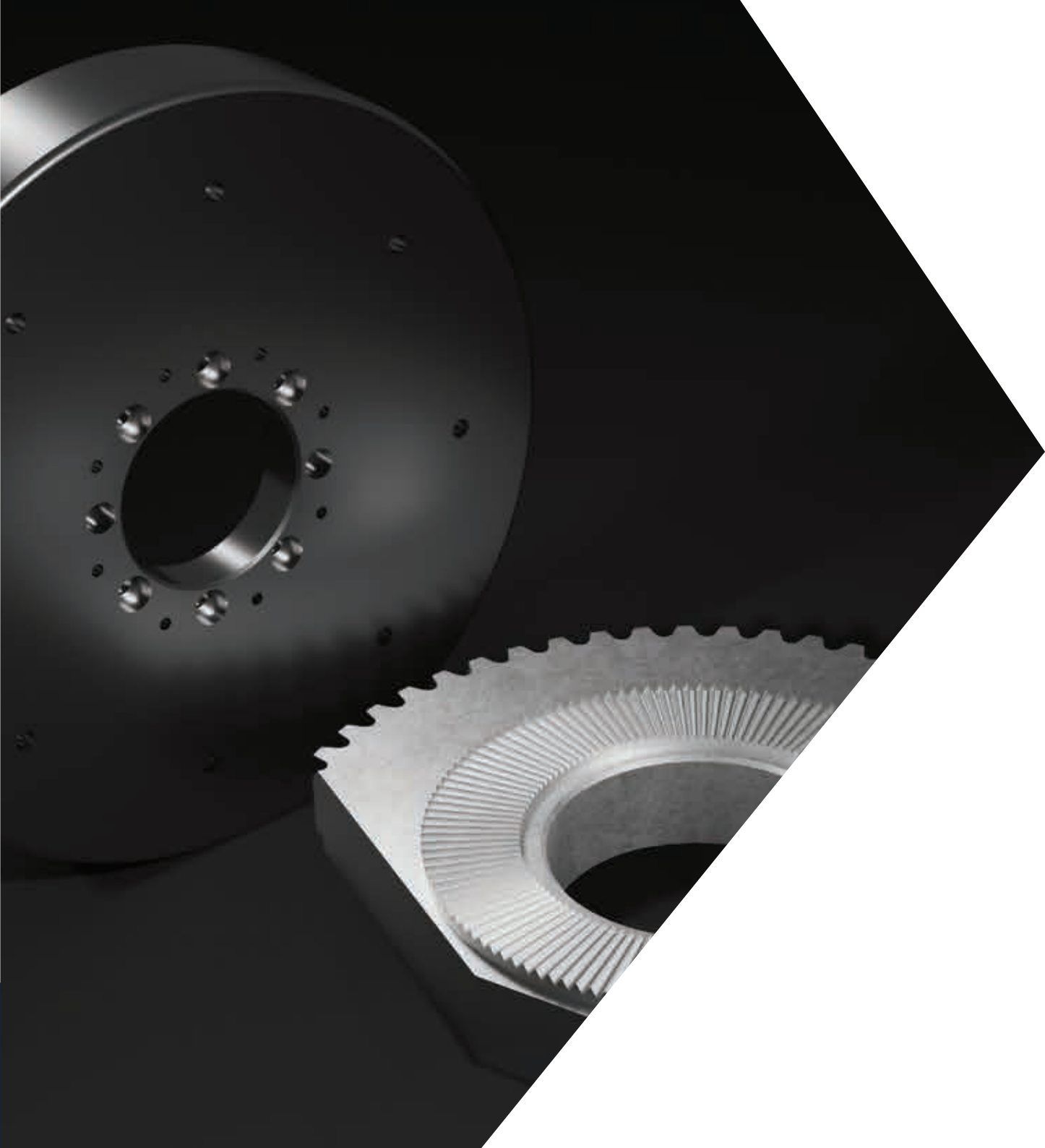

ROTARY INDEXING TABLES



ITP250 ITP400 Pneumatic Indexing Table

	ITP250	ITP400
Load Max. (6 bar)	150 kg	450 kg
Locking Force (6 bar)	780 kg	1770 kg
Drive Torque (6 bar)	35 N.m	90 N.m
Number of Indexing	4, 6, 8, 9, 12, 18, 24	4, 5, 6, 8, 10, 12, 15, 20, 24
Indexing Accuracy	±1'	±1'
Table Lift	2.5 mm	3 mm
Table Weight	45 kg	125 kg

ITEM	ITP250	ITP400
A	∅250	∅400
B	∅180	∅300
C	252	360
D	84	118
E	125	180
F	360	520
G	210	285
H	4xM8	8xM12
I	∅20	∅35
J	215	315
K	80	120
L	65	80
M	20H7	22H7
N	20x18x10	22x25x10
O	2xM16	2xM16
P	4xM6	4xM6
Q	45	65
R	∅10	∅10
S	∅30	∅40

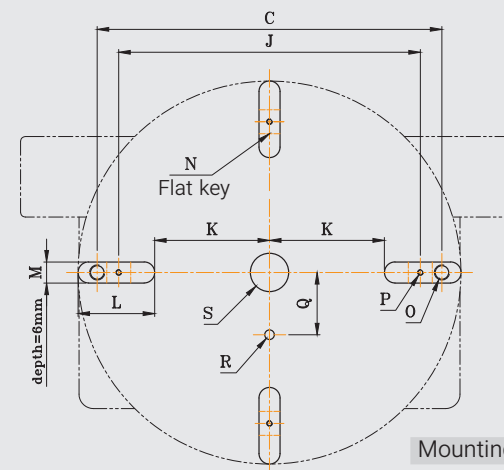
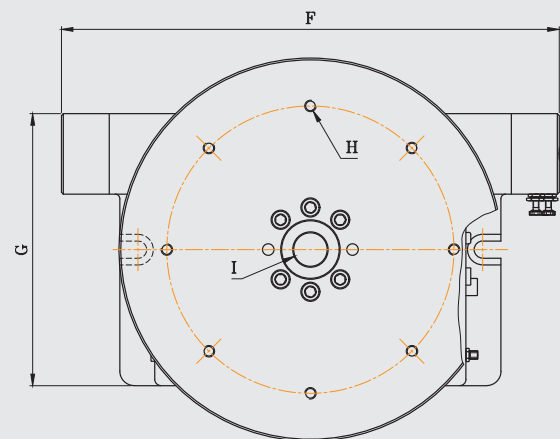
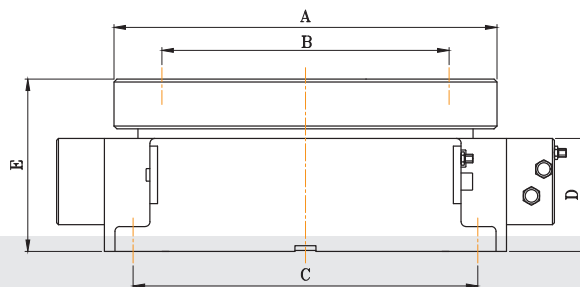
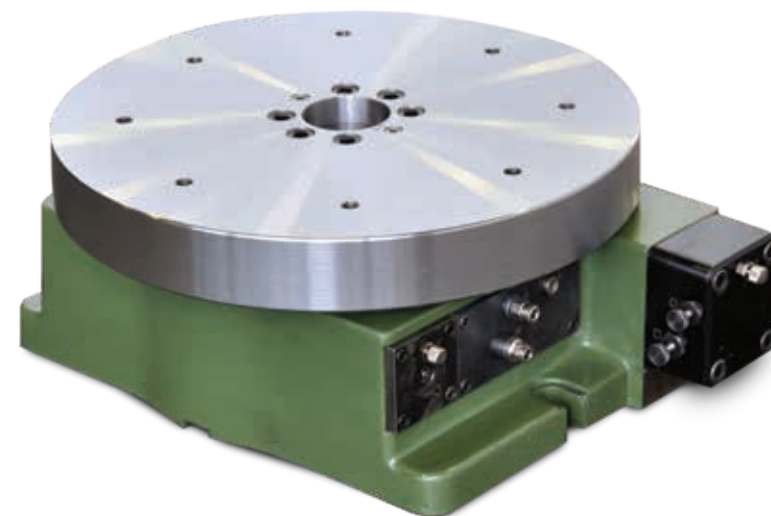

Mounting View

ITH400

Hydraulic Indexing Table



ITH400

Load Max. (30 bar)	5000 kg
Locking Force (30 bar)	5000 kg
Drive Torque (30 bar)	700 N.m
Number of Indexing	4, 5, 6, 8, 10, 12, 15, 20, 24
Indexing Accuracy	± 30"
Table Lift	6 mm
Rotation Direction	on Request
Table Weight	250 kg

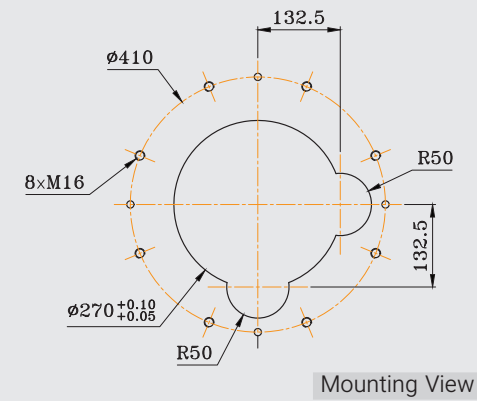
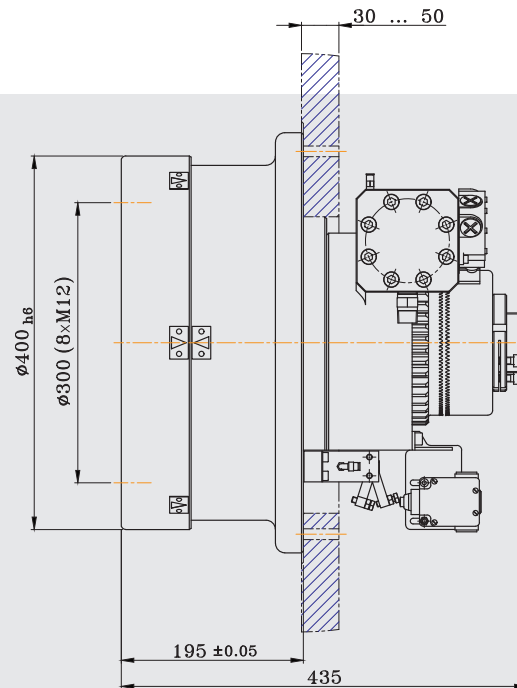
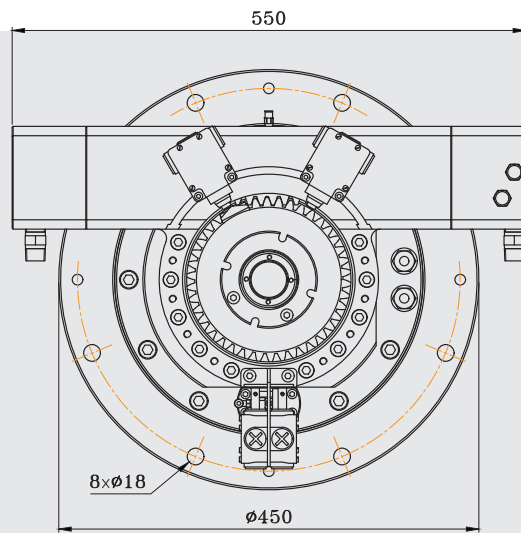

Mounting View

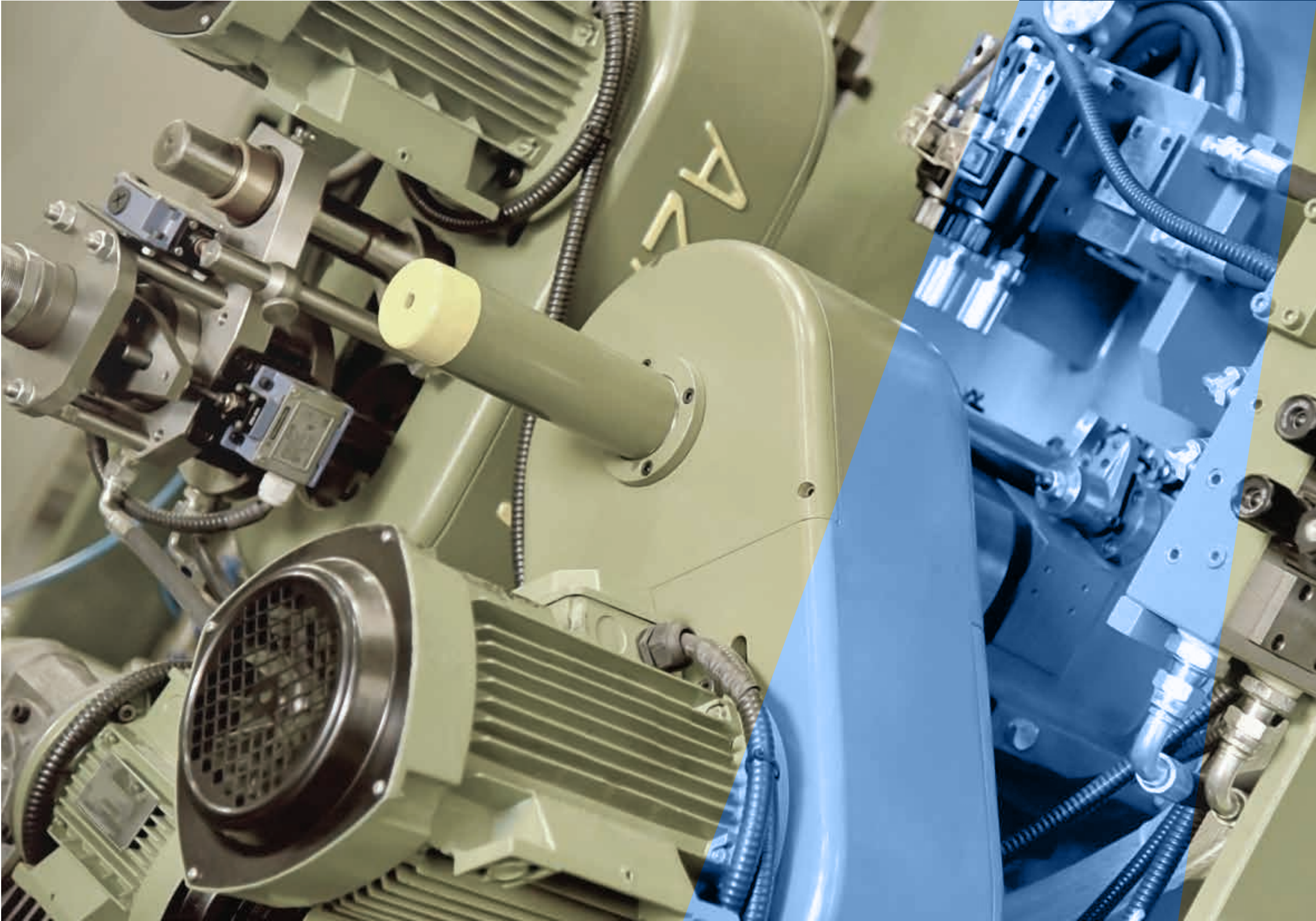



MACHINING UNITS



HBU150

Max. Drilling Capacity	ø 50 mm
Spindle Speed	450 ... 1400 (rpm)
Thrust (30 bar)	13200 N
Electric motor	as Required
Total Stroke	150 mm
Tool Holder	ISO 40
Approx. Weight	250 kg

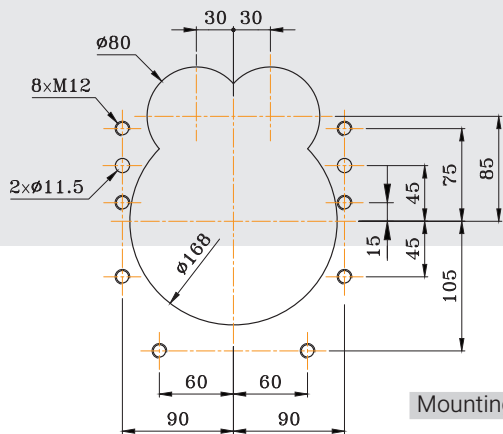
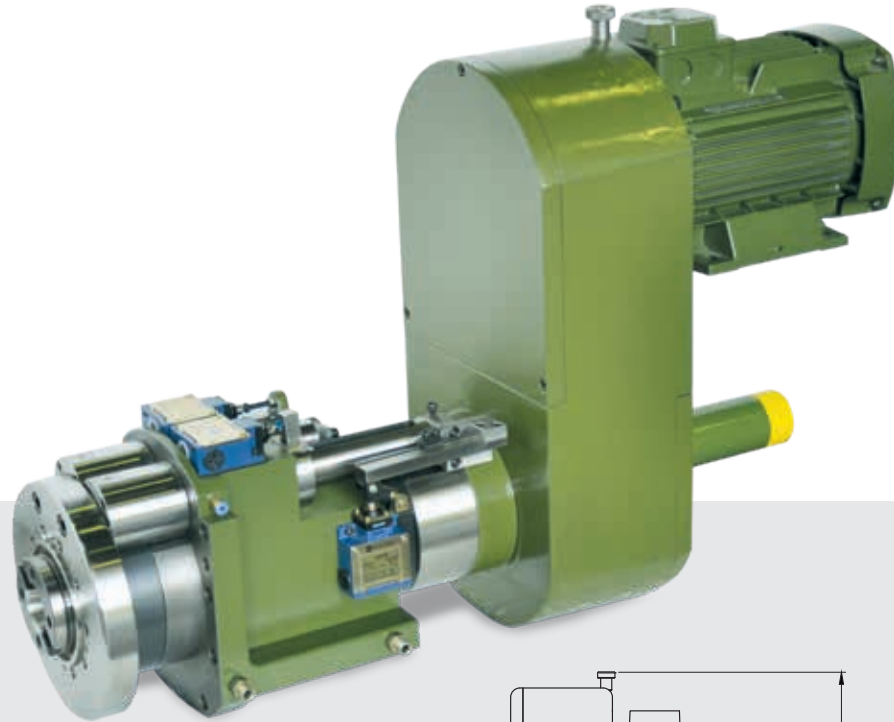

Mounting View

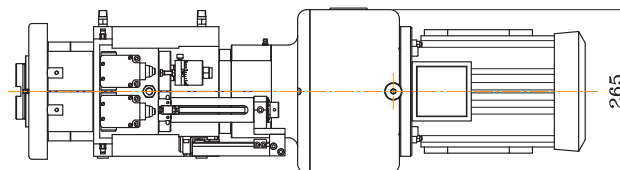
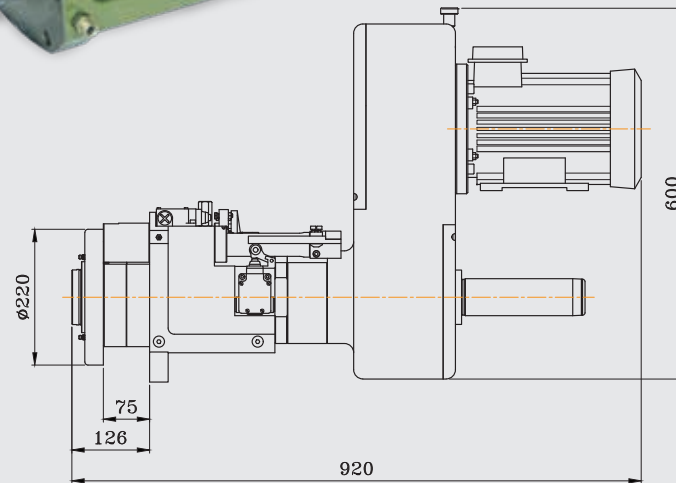

HBU150

Hydraulic Boring Unit – Type B

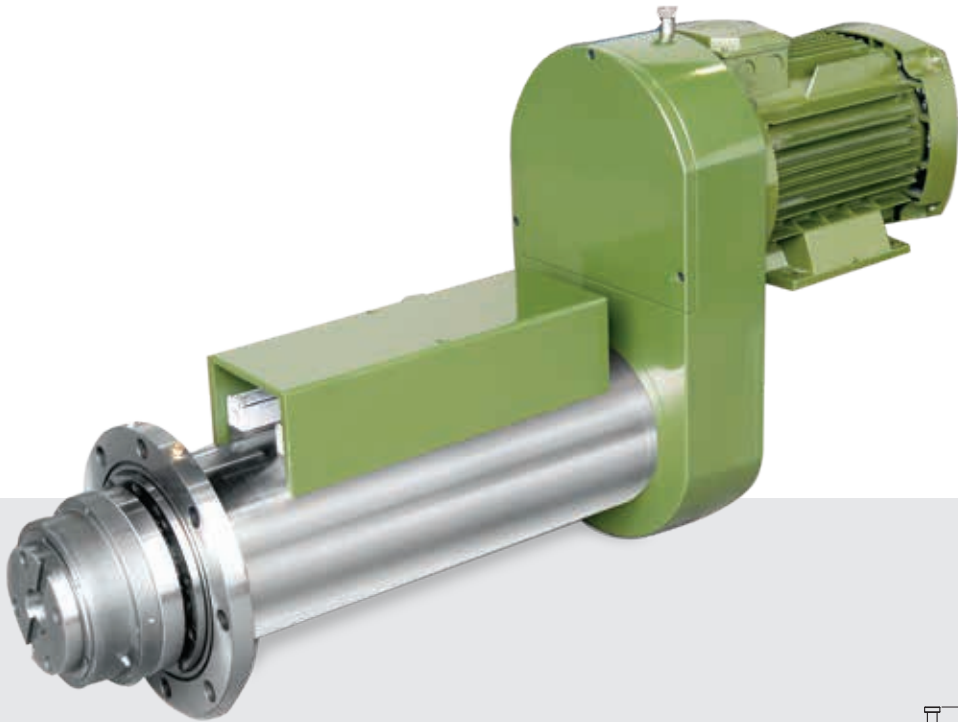

HBU150

Max. Drilling Capacity	ø 50 mm
Spindle Speed	450 ... 1400 (rpm)
Thrust (30 bar)	13200 N
Electric motor	as Required
Total Stroke	150 mm
Tool Holder	ISO 40
Approx. Weight	250 kg

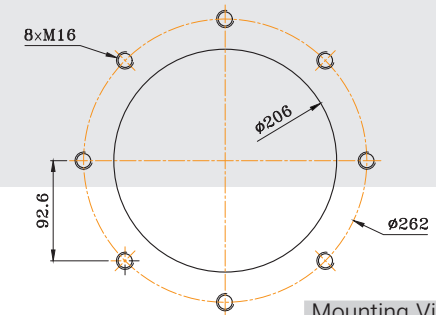
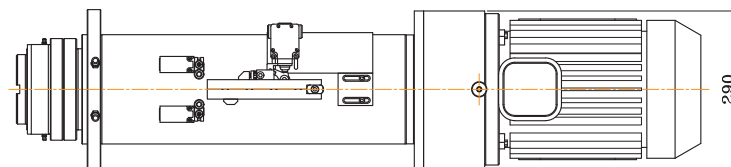
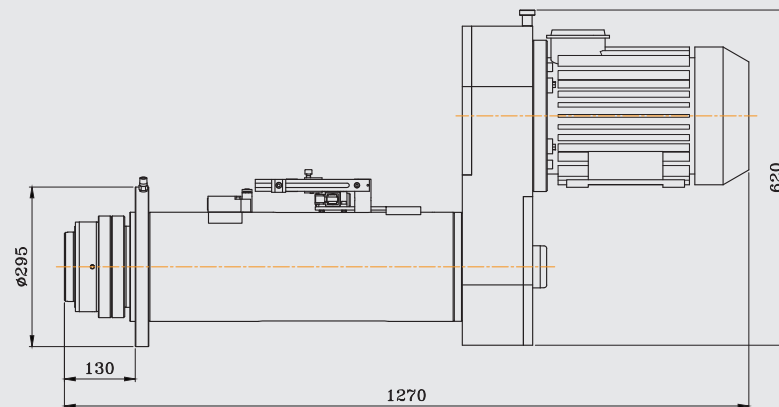

Mounting View

Type C



Type B



Type A

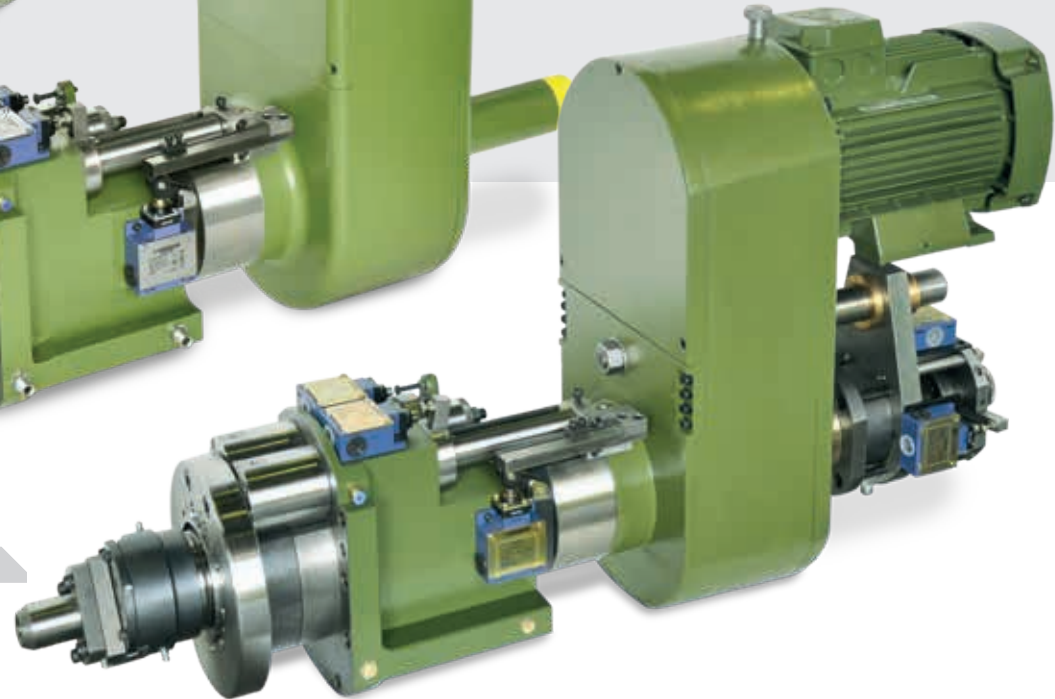

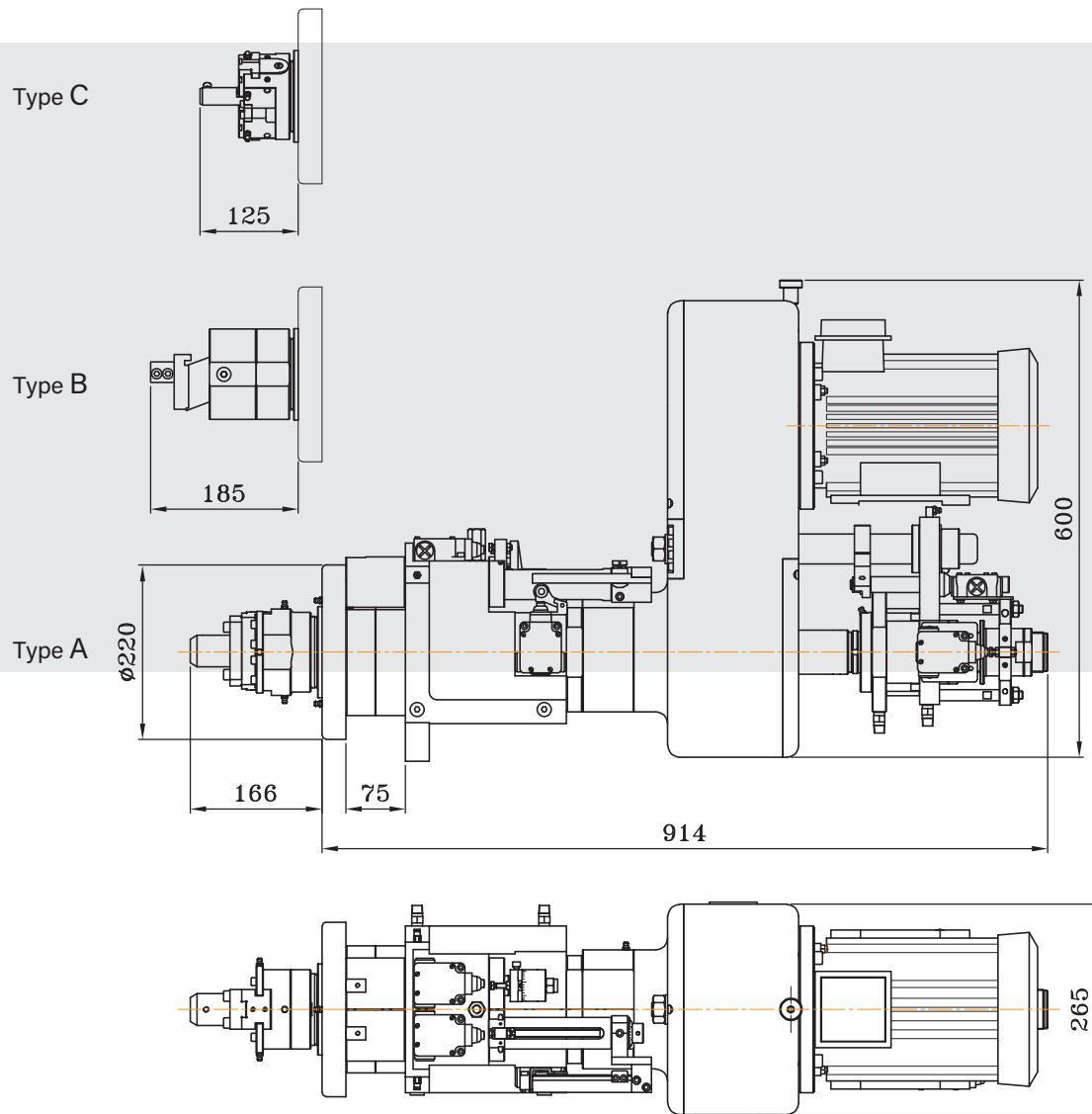

	HRU95A	HRU95B (RTHU)	HRU95C (G110)
Max. Recessing Depth	5 mm	5 mm	5 mm
Spindle Speed	900 ... 1400 (rpm)	900 ... 1400 (rpm)	900 ... 1400 (rpm)
Electric motor	as Required	as Required	as Required
Total Stroke	95 mm	95 mm	95 mm
Tool Holder	$\phi 10 \dots \phi 20$ mm on Request	$\phi 10 \dots \phi 20$ mm on Request	on Request
Approx. Weight	165 kg	150 kg	160 kg

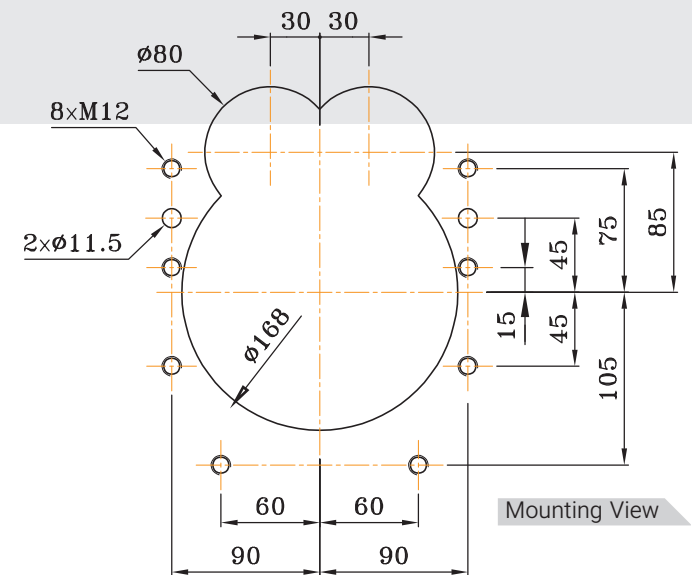

TU75 Tapping Unit

TU75

Max. Tapping Capacity	2"
Electric motor	as Required
Total Stroke	75 mm
Tool Holder	ISO 40
Approx. Weight	146 kg

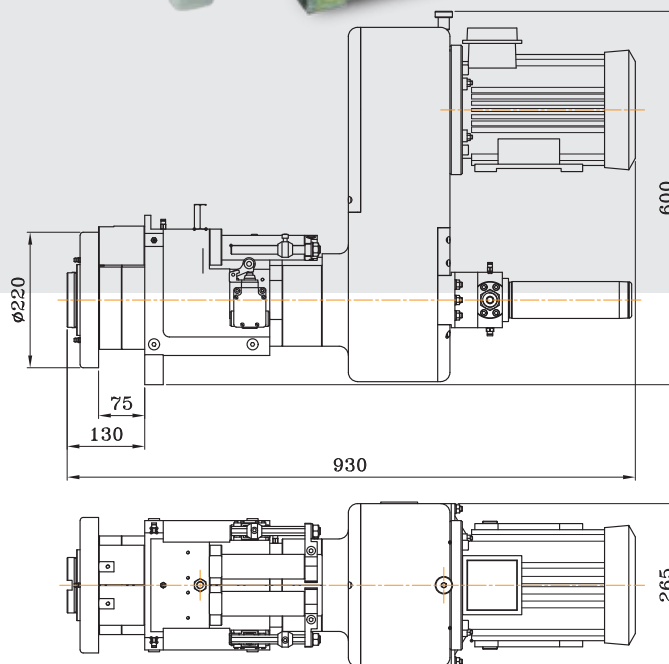
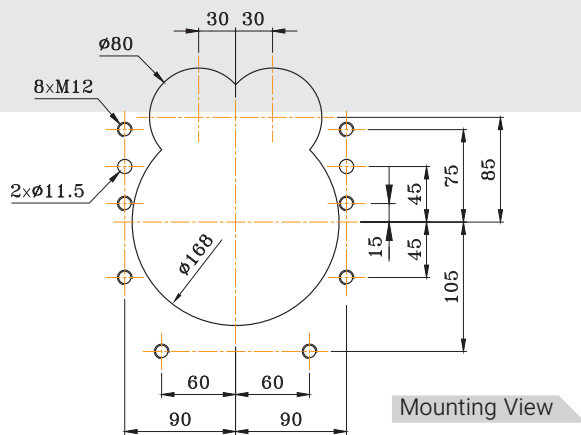
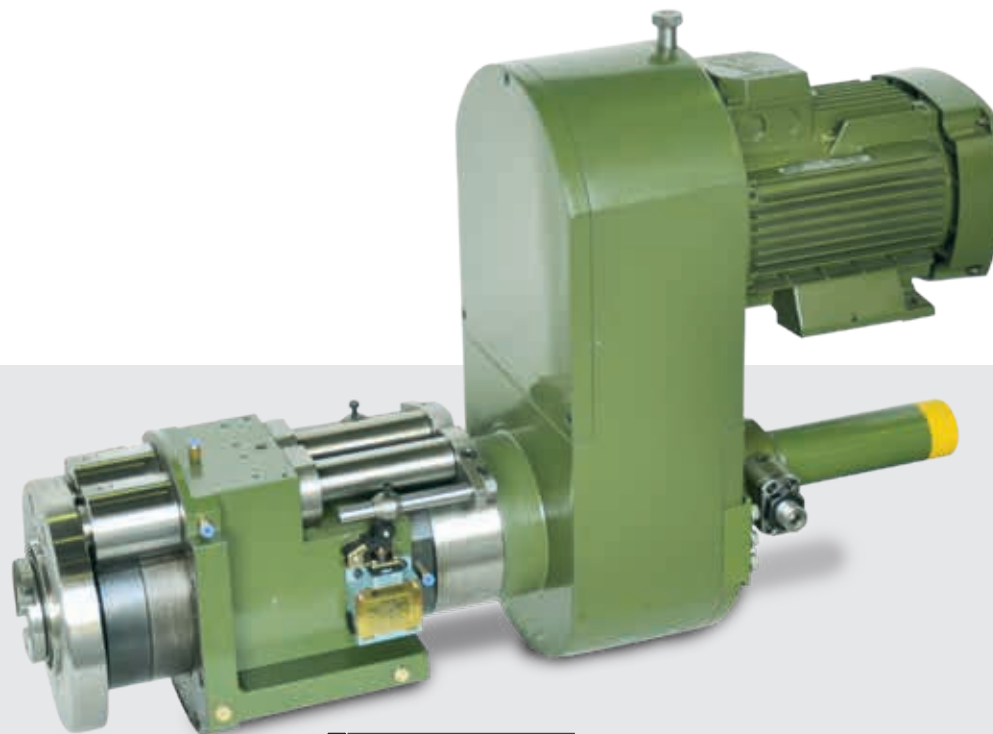

HTTU95

Hydraulic Taper Turning Unit

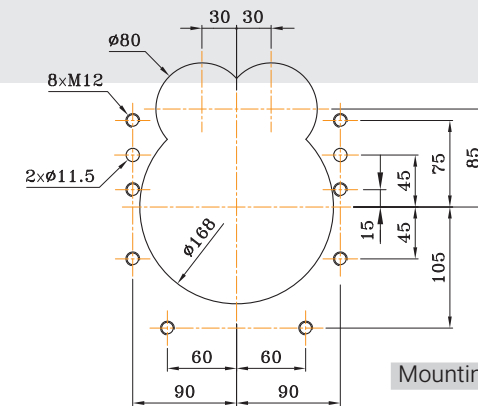
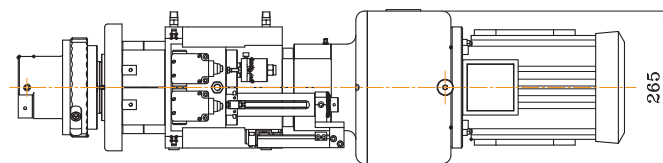
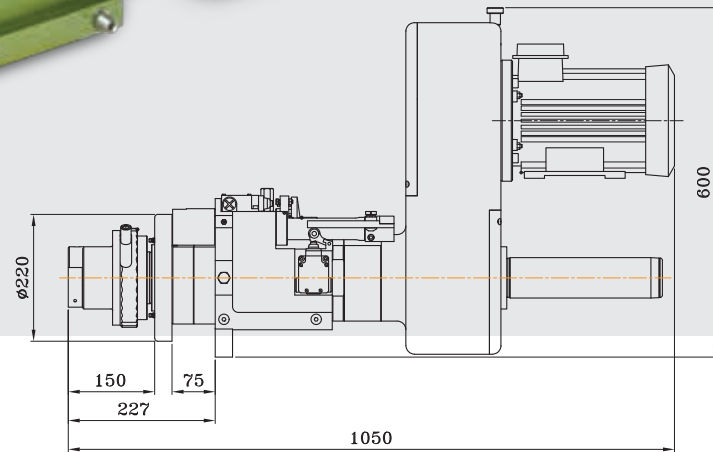

Mounting View

HTTU95	
Max. Taper Angle	1:10 ∇ on Request
Spindle Speed	900 ... 1400 (rpm)
Electric motor	as Required
Total Stroke	95 mm
Tool Holder	$\phi 10$... $\phi 20$ mm on Request
Approx. Weight	150 kg

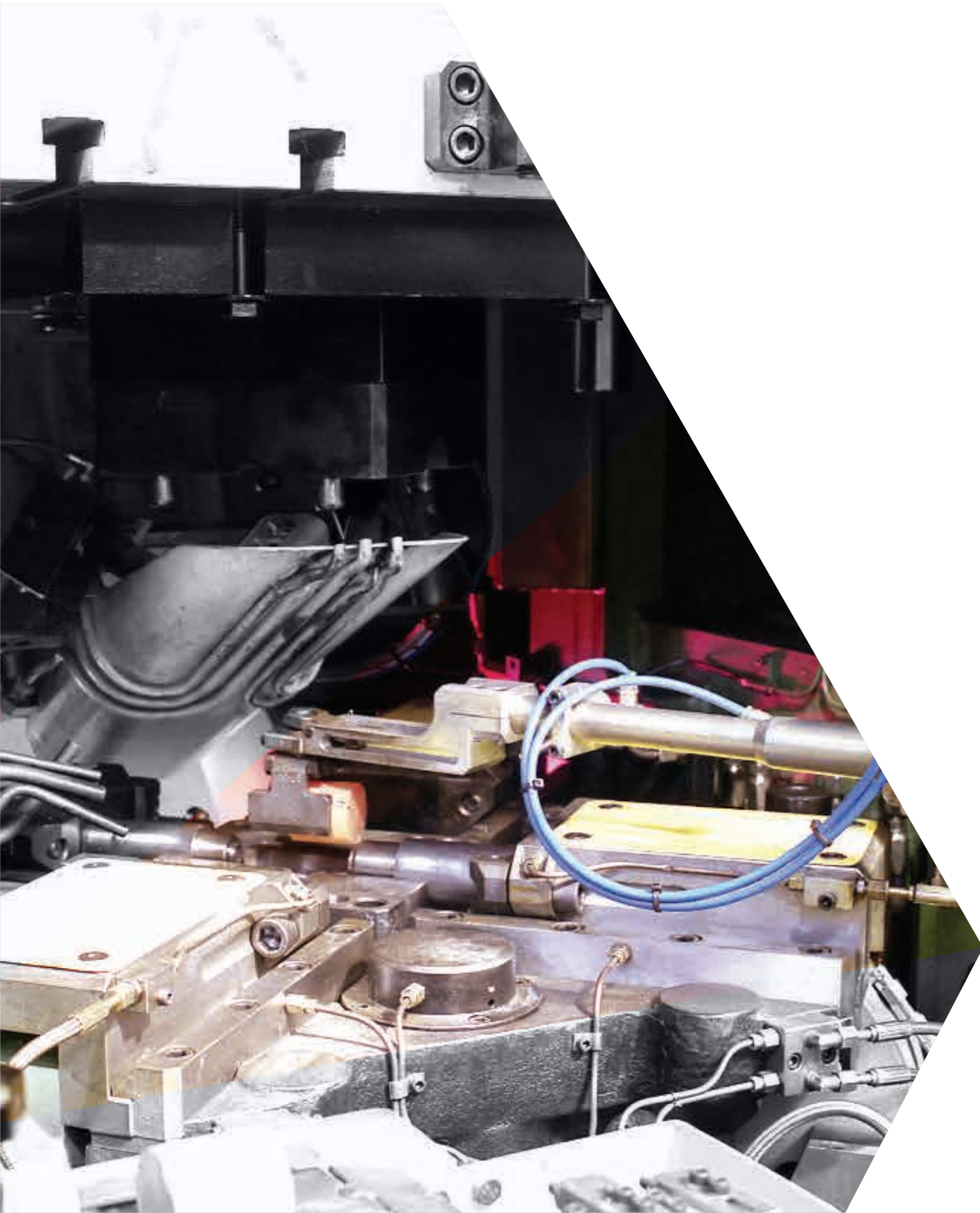

SUBPRESSES FOR HORIZONTAL/VERTICAL CORE FORGING

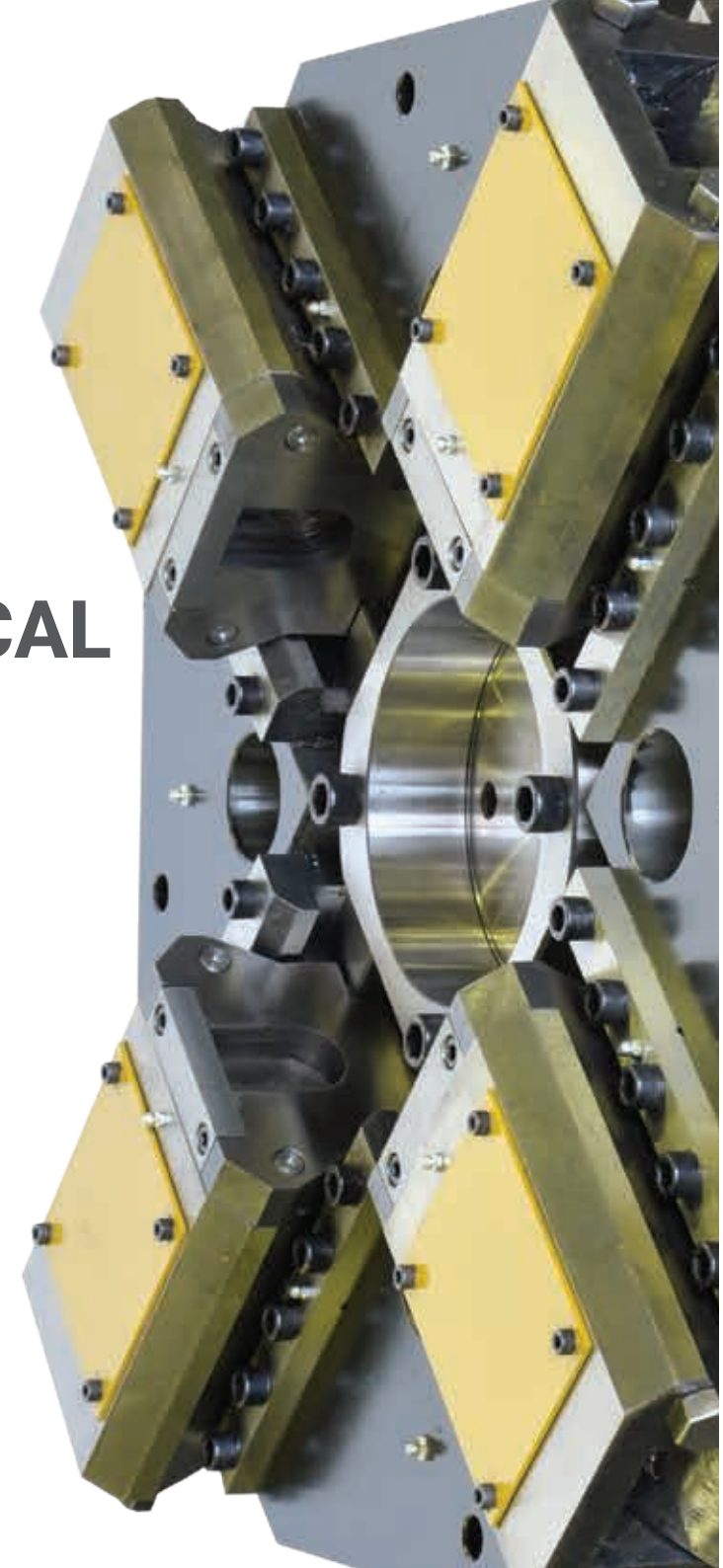

	HEU2-250	HEU2-400
Nominal Capacity	250 ton	400 ton
Total Stroke	58 mm	70 mm
Max. Die Dimension	ø175 x 80 mm	ø235 x 120 mm
Return Force	Spring	Spring
Max. Punch Diameter	ø50 mm	ø50 mm
Approx. Weight	1300 kg	1900 kg

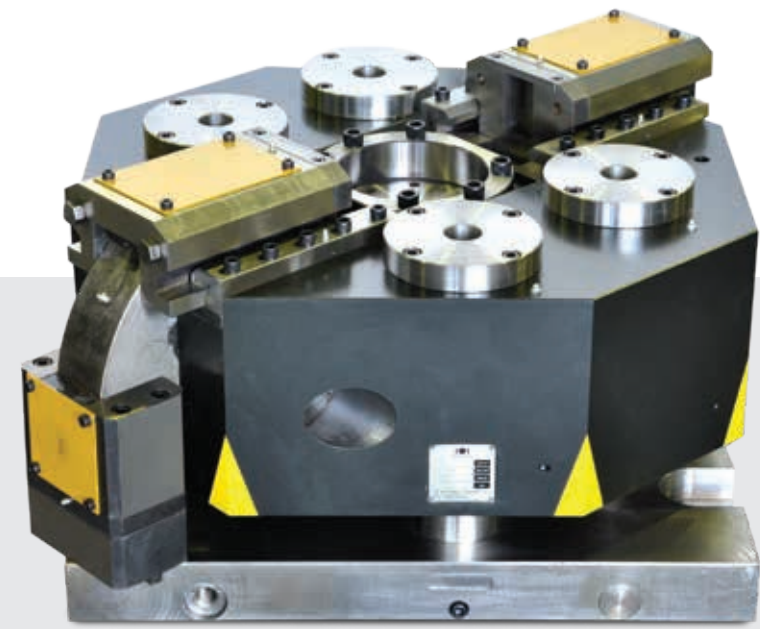

ITEM	HEU2-250	HEU2-400
A	750	880
A'	670	780
B	655	745
C	350	400
D	473	565
E	4xM24	6xM24

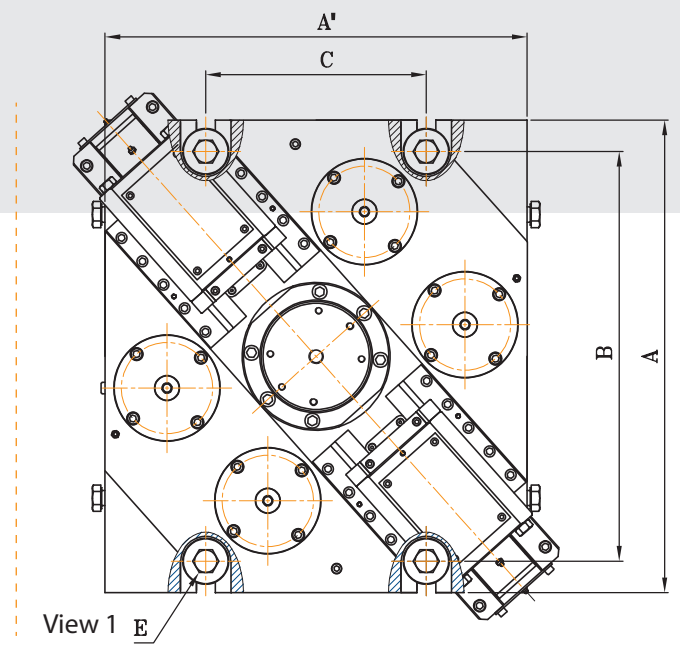
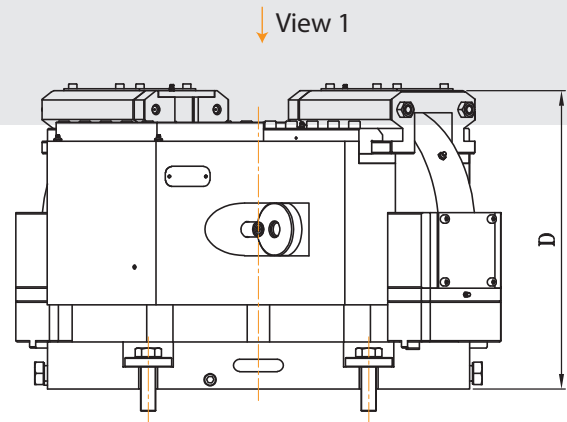

HEU4-100 HEU4-160 HEU4-250

4 Way - Horizontal Extrusion Unit

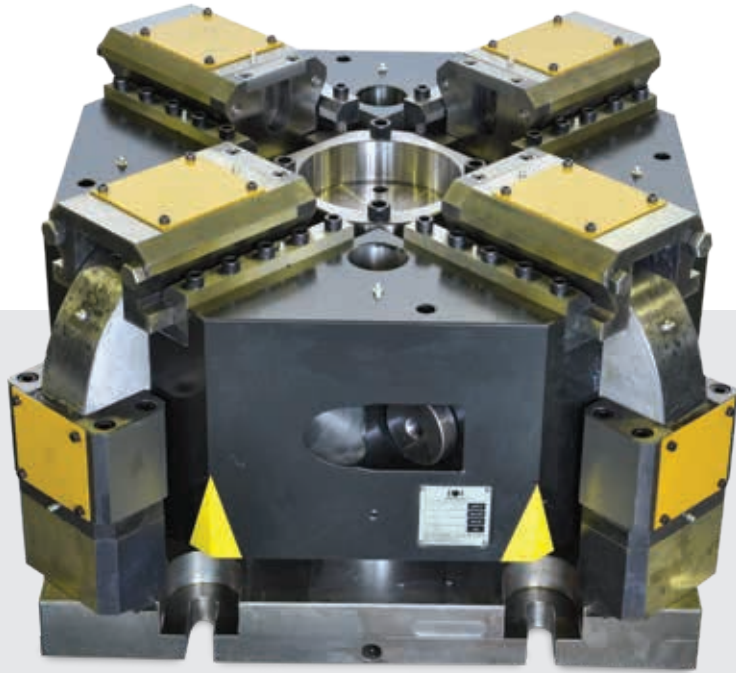

	HEU4-100	HEU4-160	HEU4-250
Nominal Capacity	100 ton	160 ton	250 ton
Total Stroke	40 mm	45 mm	52 mm
Max. Die Dimension	ø140 x 70 mm	ø140 x 70 mm	ø175 x 80 mm
Return Force	Spring	Spring	Spring
Max. Punch Diameter	ø40 mm	ø40 mm	ø55 mm
Approx. Weight	550 kg	830 kg	1200 kg

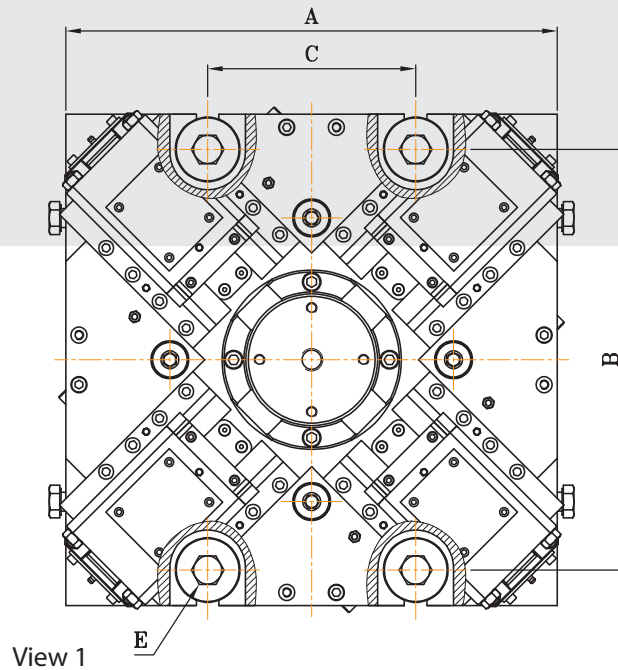
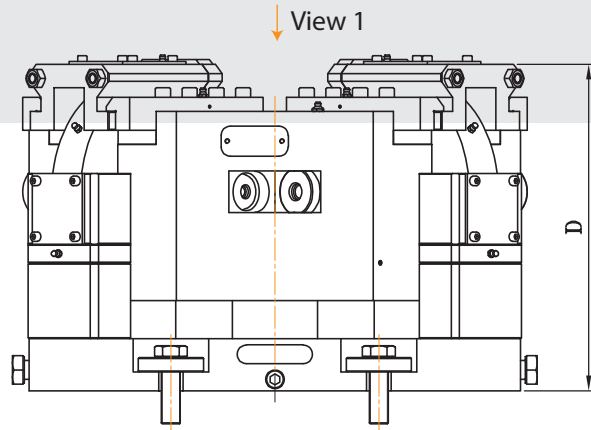

ITEM	HEU4-100	HEU4-160	HEU4-250
A	520x520	580x580	670x670
B	445	500	575
C	220	220	350
D	345	410	467
E	4xM20	4xM20	4xM24



	VEU-100	VEU-100B	VEU-250	VEU-400
Nominal Capacity	100 ton	100 ton	250 ton	400 ton
Total Stroke	20 mm	25 mm	36 mm	41 mm
Max. Die Dimension	ø135 x 70 mm	ø135 x 70 mm	ø175 x 80 mm	ø235 x 95 mm
Return Force	Spring	Spring	Spring	Spring
Max. Punch Diameter	ø40 mm	ø40 mm	ø60 mm	ø107 mm
Approx. Weight	160 kg	210 kg	255 kg	530 kg

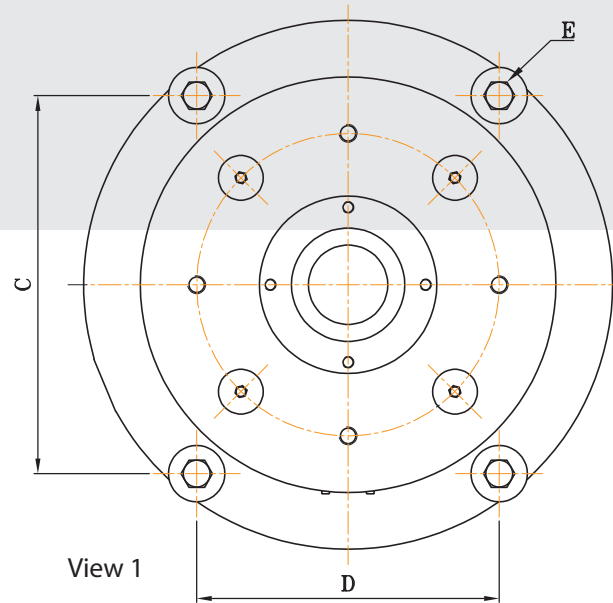
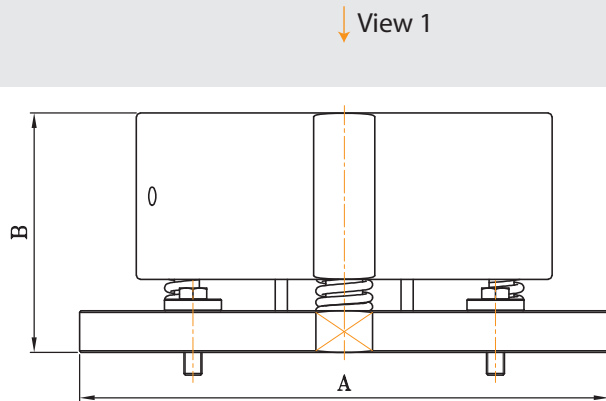

ITEM	VEU-100	VEU-100B	VEU-250	VEU-400
A	400x400	400x400	ø500	ø700
B	170	225	290	316
C	300	300	280	500
D	300	300	350	400
E	4xM16	4xM16	4xM20	4xM24



TRIMMING PRESSES



TP05Wi TP10Wi TP30Wi

Trimming Press (Without Indexing Table) ☰

	TP05Wi	TP10Wi	TP30Wi
Nominal Force (50 bar)	5 ton	10 ton	30 ton
Total Stroke	138 mm	138 mm	250mm
Electric motor	4 (kw) 1400 (rpm)	4 (kw) 1400 (rpm)	5.5 (kw) 1400 (rpm)
Approx. Weight	830 kg	840 kg	1960 kg

ITEM	TP05 - 10Wi	TP30Wi
A	2000	2400
B	750	900
C	840	1500
D	240	455
E	835	790

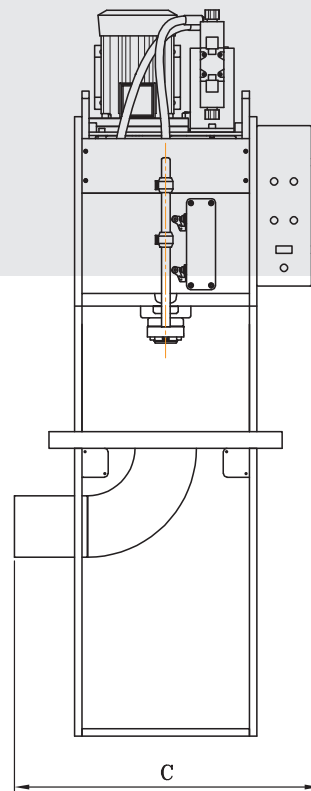
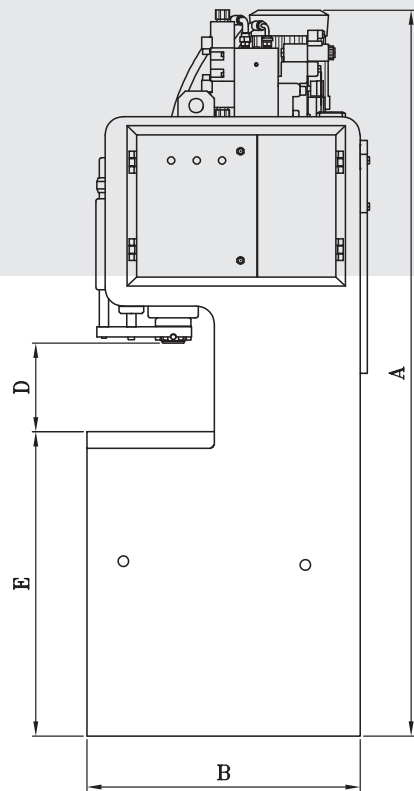

TP05Hi TP10Hi

Trimming Press (With Hydraulic Indexing Table) ☰

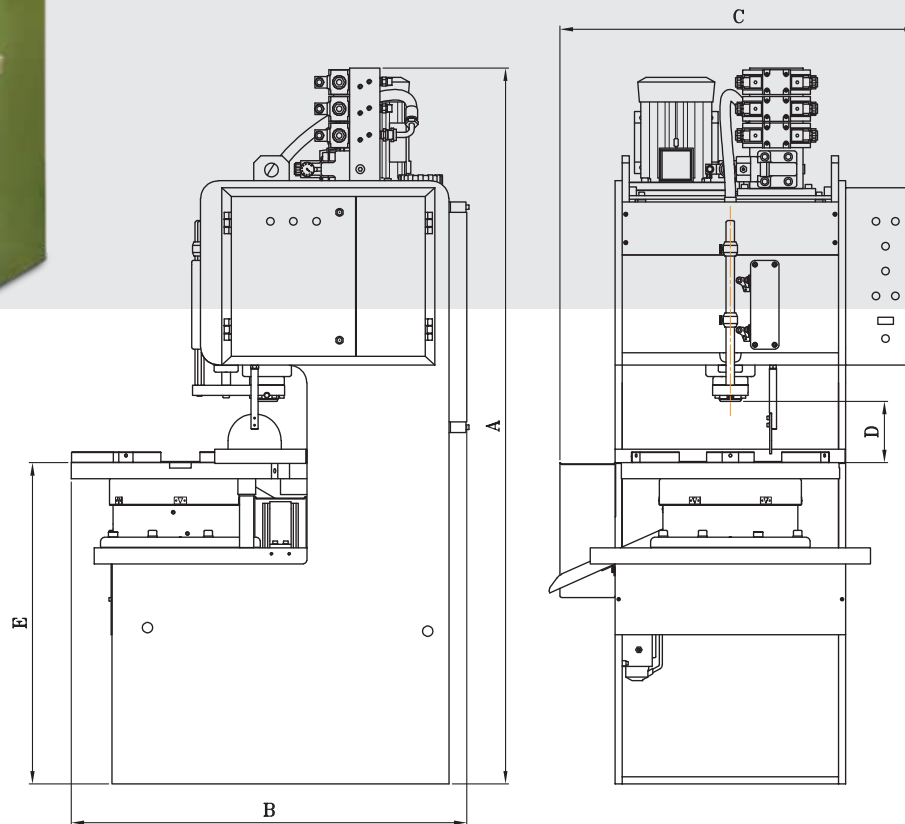

	TP05Hi	TP10Hi
Nominal Force (50 bar)	5 ton	10 ton
Index Type	ITH400	ITH400
Total Stroke	135 mm	135 mm
Electric motor	4 (kw) 1400 (rpm)	4 (kw) 1400 (rpm)
Approx. Weight	1450 kg	1500 kg

ITEM	TP05Hi	TP10Hi
A	2020	2020
B	1115	1215
C	1010	1010
D	170	220
E	905	855



HYDRAULIC WRENCH MACHINES

HSM200 HSM320

Hydraulic Torque Wrench Machine



	HSM200	HSM320
Hydraulic Motor	200 Cm ³ /u	320 Cm ³ /u
Max. Drive Torque (150 bar)	190 N.m	300 N.m
Max. Speed (150 bar)	120 U/min	120 U/min
Total Stroke	150 mm	150 mm
Approx. Weight	710 kg	820 kg

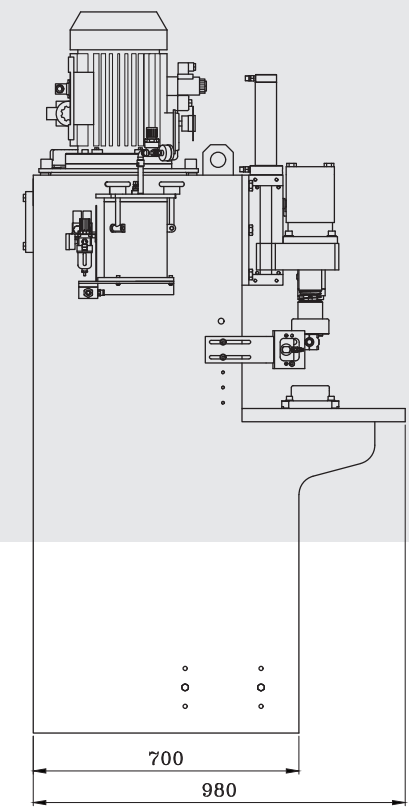
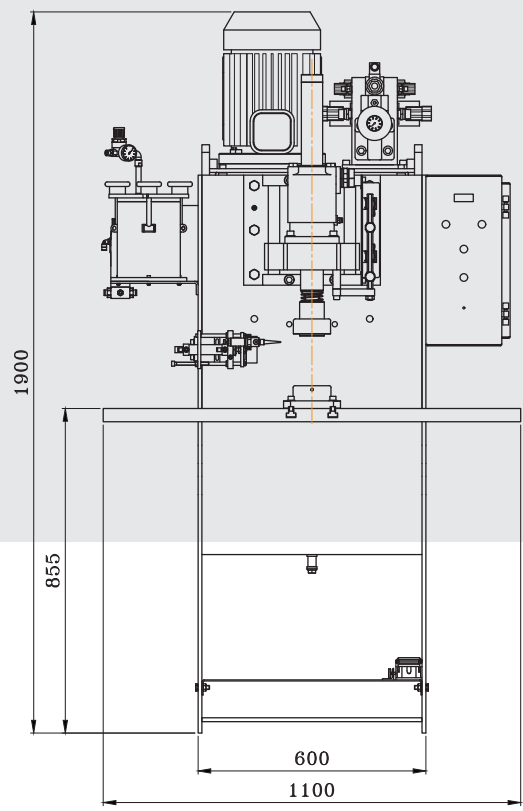



HYDRAULIC POWER UNITS

HPU40V/40-90

Hydraulic Power Unit

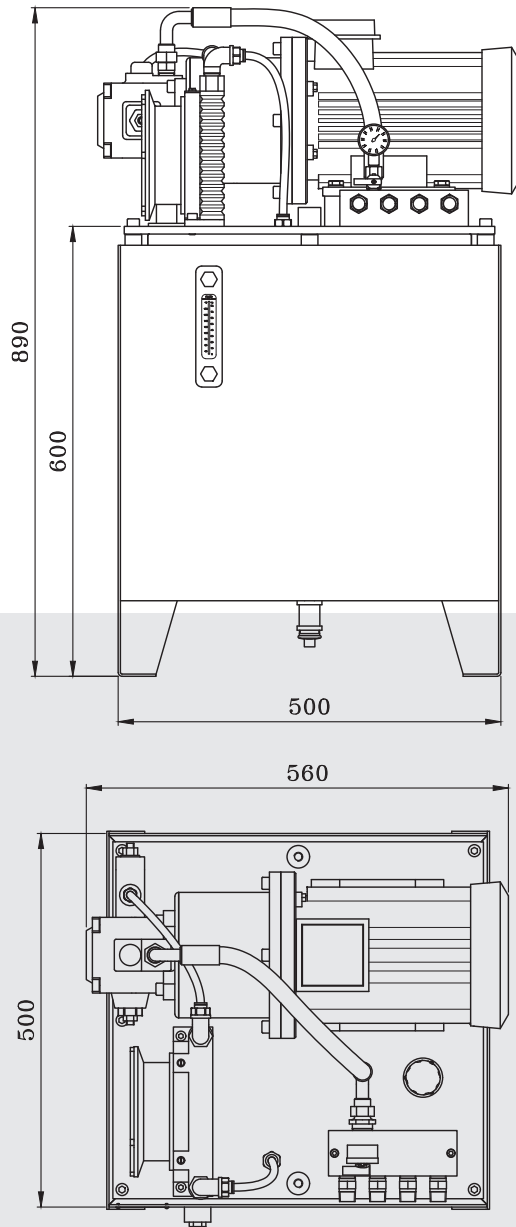

HPU40V/40-90

Tank Capacity	90 Liter
Max. Pressure	40 bar
Electric motor	3 (kw) 1400 (rpm)
Max. Flow Rate	40 (liter / min)
Hydraulic Manifold	on Request
Hydraulic Valves	on Request
Cooling System	on Request

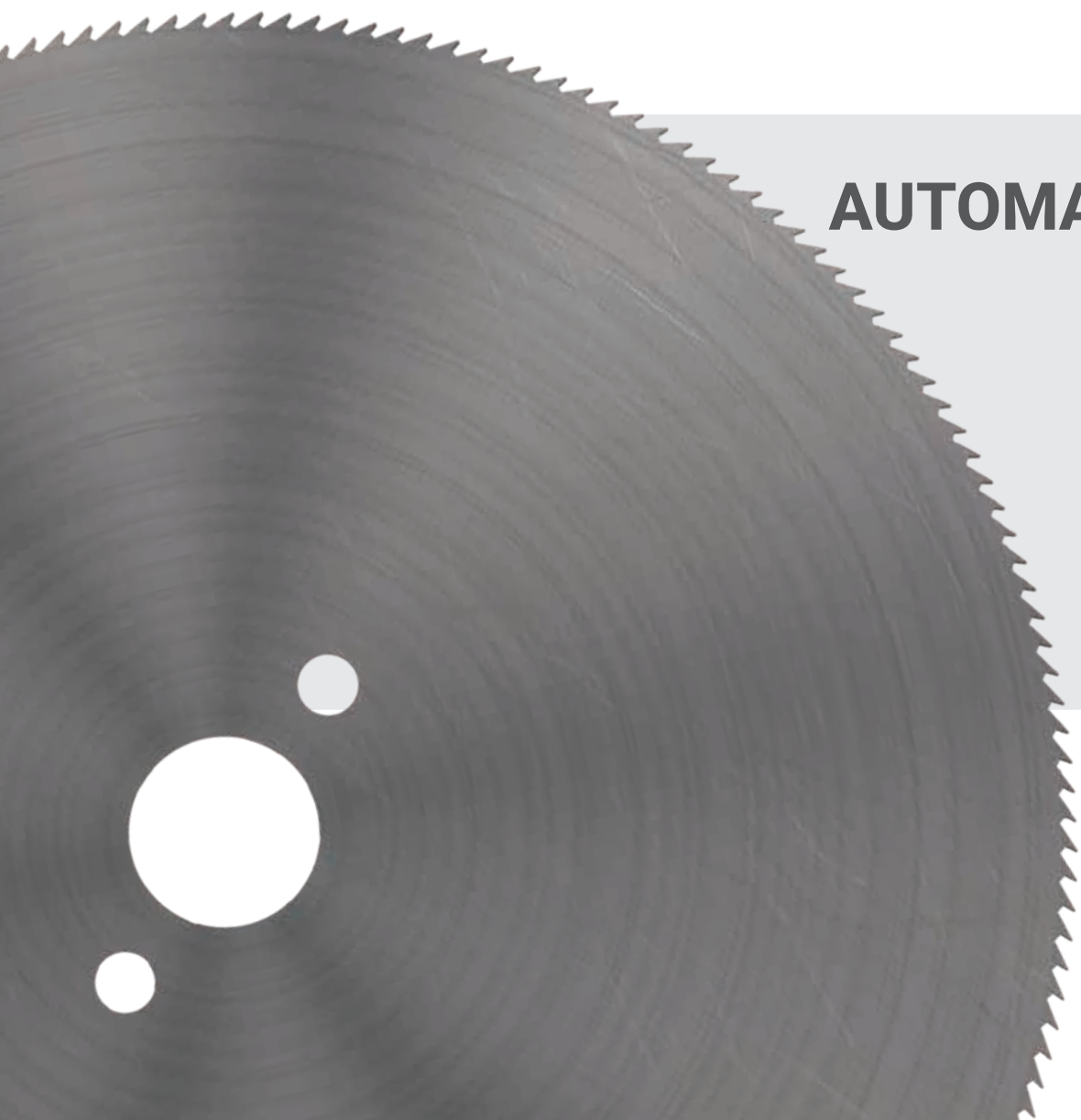

AUTOMATIC CIRCULAR SAW MACHINES

ASM300

Automatic Circular Saw Machine

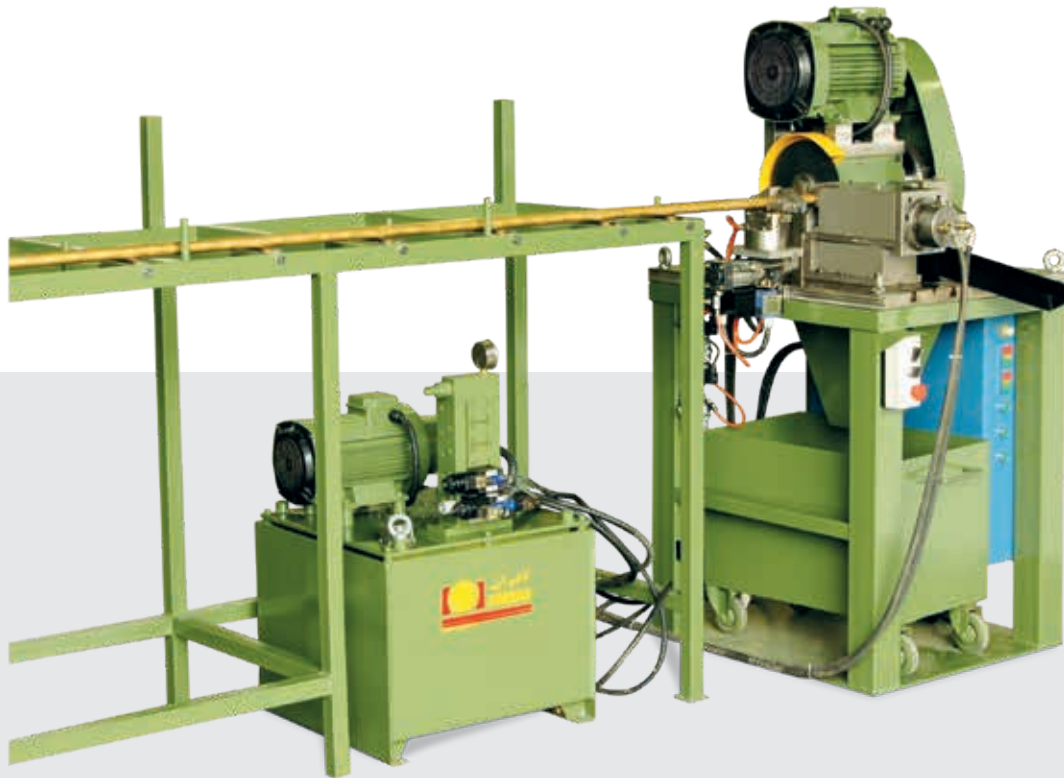

ASM300

Max. Circular blade size	ø300 mm
Blade Rotation Speed	520 u/min
Max. Cutting Diameter (Auto Feed)	ø20 - ø50 mm (A پاتس) ø40 - ø80 mm (B ستاپ)
Max. Cutting Length (Auto Feed)	80 mm
Max. Cutting Speed	490 m/min
Electric motor	5.5 (kw) 1400 (rpm)
Hydraulic power unit	HPU90
Approx. Weight	900 kg

View 1

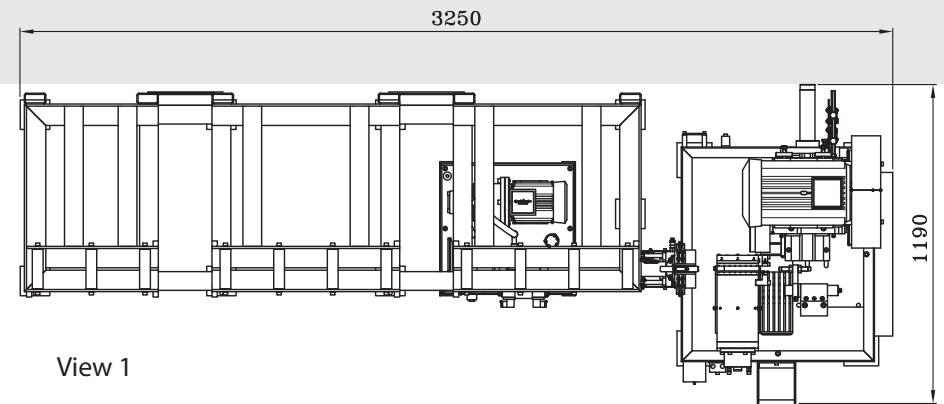
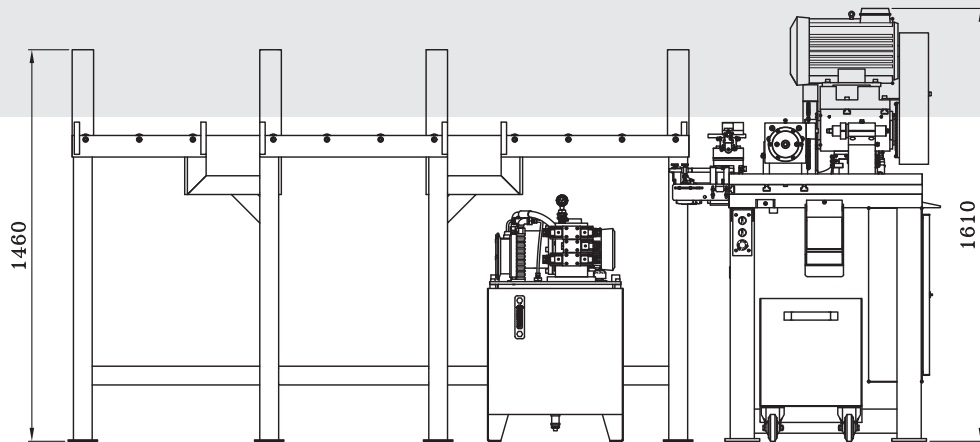







Contact Us:

 +98 31 3572 4995-8

 www.azaran-group.com

 Jey Industrial Town, Isfahan - Iran
Shop1, Nakheel Rd, Diera Dubai - UAE

 info@azaran-group.com





www.azaran-group.com